

# Enduro<sup>TM</sup> ELITE

## SM1050-2

NON-POSITIONER SERVO MOTOR  
ENGLISH USER INSTRUCTIONS & PARTS LISTING

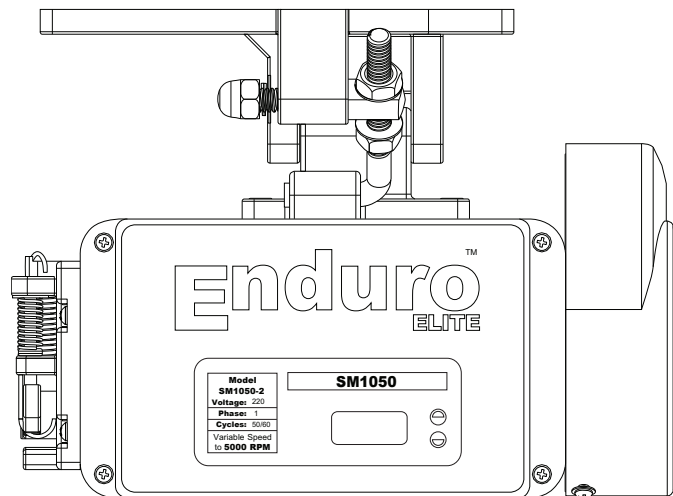

**SM1050-2 ENDURO<sup>TM</sup> ELITE**

INSTRUCTIONS - PAGE 2 >  
PARTS LISTING - PAGE 11 >

# SM1050-2 ENDURO™ ELITE NON-POSITIONER SERVO MOTOR USER INSTRUCTIONS

## Congratulations!

You have purchased the Enduro™ Elite SM1000 series motor that pays for itself with 60% to 80% energy savings compared to clutch motors. With the high and rising cost of electricity, you just can't afford to run a clutch motor any longer. The power and dependability of the brushless Enduro™ Elite SM1000 series is exceptional. This workhorse just won't quit.

Please read these instructions carefully before installation, operation or maintenance.

## General Introduction

The Enduro™ Elite SM1000 Series Servo Motor is designed to meet almost all basic heavy duty and continuous use requirements of various industrial sewing machines. It utilizes extremely powerful rare-earth Neodymium permanent magnets. The motor produces almost no noise, saves energy and is brushless, speed adjustable and durable. It provides a high starting torque even at low speed or from a complete stop.

By using a modern technologically advanced microprocessor, Hall sensor and Pulse-Width Modulation technology, the Enduro™ Elite SM1000 series can be set to rotate at different maximum speeds, in either normal or reverse directions, and can start with different accelerating speeds. It will stop automatically with any interruption such as in-line voltage, electrical surge, radio frequency interference or overloading. It is fully protected by the software and will give error messages indicating which problem is encountered. It even works well in environments with an unstable electrical power supply.

## CAUTION

1. Remove your foot from the pedal when turning the power ON.
2. Turn the power switch OFF before replacing or threading the needle.
3. Turn the power switch OFF when leaving the machine.
4. **When performing maintenance on the sewing machine, turn the motor power switch to the OFF position. Remove the power cord from the back of the motor to completely disable all power to the sewing machine.**
5. Always ground the grounding wire.
6. **Always turn off the power switch before connecting or disconnecting each connector.**
7. **To avoid an accident, do not alter this motor and control box.**

## Warranty

This product is covered with a 1 year limited warranty. If the motor fails to perform its designed function due to manufacturer's defects, contact the place you purchased it from for repair or replacement.

This warranty does not cover defects due to dropping, power surge, spikes or misuse.

## Installation

Put the mounting bracket of the motor upwards to the bottom of the tabletop and fix the motor to the tabletop with the bolts provided. Connect the treadle rod with the connecting rod joint. Install the female plug of the cable from the switch box into the power inlet socket in the back of the motor box.

## Wiring

**For 220 volt single phase motor follow the diagram below:**

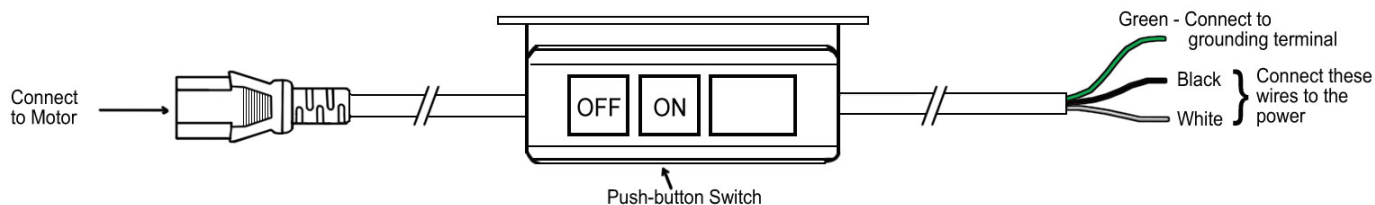

**Note:** When wiring the motor to the power source, connect both the black and white wires to achieve 220 Volts (green to ground). If you are in an area (China / Europe) that supplies 220 Volts from a single lead, then connect the power source to the black wire. The white wire will then be the neutral and the green wire will be the ground.

## Setting Up

Turn on the power switch located on the switchbox. The display will show roughly a circle with a running blinking bar, which means the motor is now in **"ready" status**, ready to work or be set.

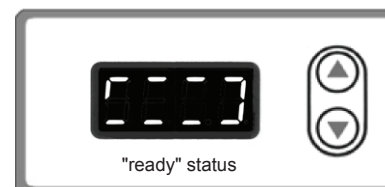

### Motor Rotating Direction Setting

#### Setting up Number 2

- a. Keep "▼" button pressed for several seconds, until LED display indicates **"SET.0"**.
- b. Press "▲" button 2 times. It will now indicate **"SET.2"**, which means **"Setting up No. 2"**.
- c. Press "▼" button until the LED indicates **"roT.E"** or **"roT.P"**. Press "▼/▲" to switch between E and P, to meet the desired requirement.  
 "E" means the motor will run in reversed direction.  
 "P" means the motor will run in normal direction.
- d. Setting will be automatically saved 5 seconds after no buttons are pressed. The motor returns to **"ready" status**.

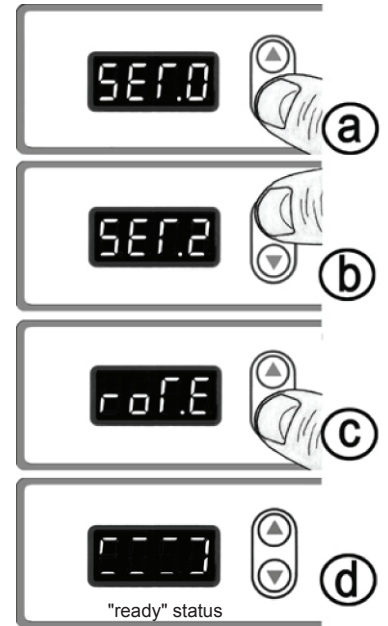

### Slow Starting Speed

#### Setting up Number 1

1. The "slow period time" = 128milliseconds \* X, (slow starting setting), X = 0~9 (as setting up in the motor).
2. Example: The treadle is depressed approximately half way down producing a motor speed of about 2,000 RPM and if the Slow Starting is set at **9**, then the time from 0 to 2000RPM is theoretically 128 milliseconds X 9 = 1152 milliseconds, plus the electrical-mechanical delay which is about 0.8 seconds.
3. If the Slow Starting is set at 0, the "real starting time" and time from 0-2000RPM is about 0.8 seconds, which is due to the unavoidable electrical-mechanical delay.

### Option A - Setting Slow Starting Speed via Motor Control

- a. Keep "▼" button pressed for several seconds, until LED display indicates **"SET.0"**.
- b. Press "▲" button 1 time to indicate **"SET.1"**, which means **"Setting up No. 1"**.
- c. Press "▼" button and LED indicates **"SOT.X"** (X is 0-9). Press "▼/▲" to adjust from 0 to 9 according to your own application. 0 means the quickest. 9 means the slowest. The manufacturer's default setting is 0.
- d. Setting will be automatically saved 5 seconds after no buttons are pressed. The motor returns to **"ready" status**.

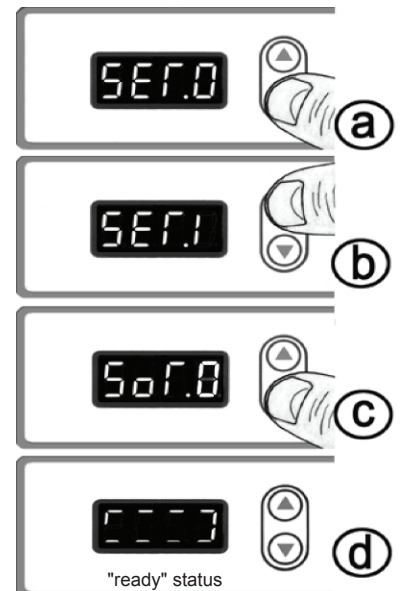

## Option B - Setting Slow Starting Speed Manually

The larger the gap between the slow start shaft and the treadle bar the faster the initial starting speed.

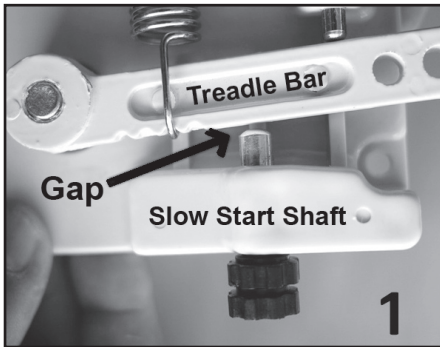

1. Notice the small gap between the slow start shaft and the treadle bar.

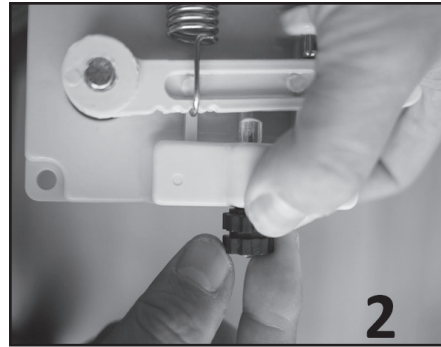

2. Unscrew the lower nut while holding the upper one to loosen them from each other.

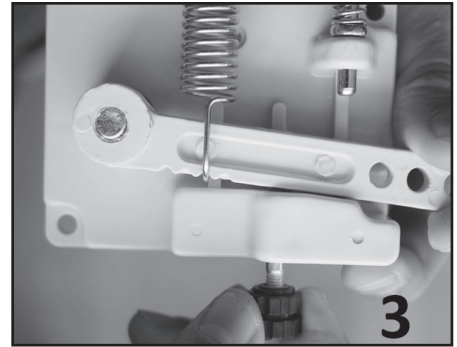

3. Press the treadle bar down, to force the shaft to move downward.

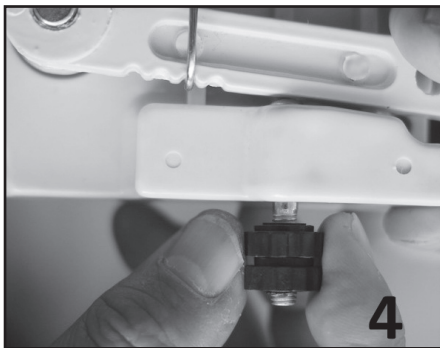

4. Turn both the screw nuts to make them move upward.

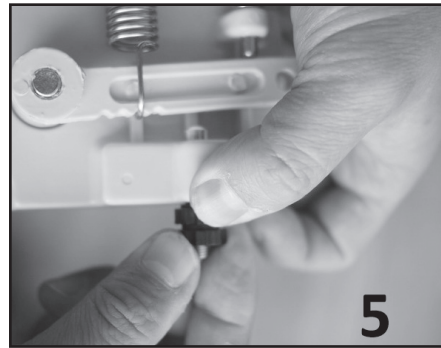

5. Tighten the two nuts against each other.

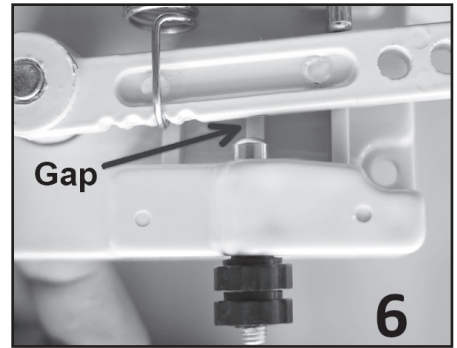

6. The larger gap the faster the initial starting speed.

**Maximum Speed Setting  
Setting up Number 3**

- a. Keep "▼" button pressed for several seconds, until LED display indicates "SET.0".
- b. Press "▲" button 3 times to indicate "SET.3", which means "Setting up No. 3".
- c. Then press "▼" button and LED shows 100-5000, which means the highest motor speed in RPM.  
  
Press "▼/ ▲" to adjust the Maximum Speed from 100rpm to 5000rpm. The manufacturer's default setting is 3800rpm.
- d. Setting will be automatically saved 5 seconds after no buttons are pressed. The motor returns to "ready" status.

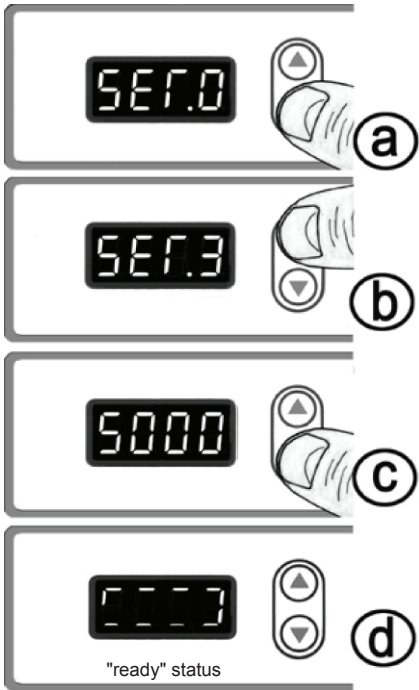

STITCHES PER MINUTE AT 1000 RPM MOTOR SPEED								
MOTOR PULLEY DIAMETER	SEWING MACHINE HANDWHEEL PULLEY SIZE							
MM / INCHES	55 = 2-1/8	60 = 2-3/8	65 = 2-5/8	80 = 3-1/4	100 = 4	120 = 4-3/4	140 = 5-5/8	160 = 6-3/8
50 = 2	925	850	775	625	500	425	350	315
60 = 2-3/8	1100	1000	925	750	600	500	425	375
75 = 3	1375	1250	1150	935	750	625	525	475
80 = 3-1/4	1500	1350	1250	1000	800	675	575	500
90 = 3-5/8	1625	1500	1400	1125	900	750	650	565
100 = 4	1750	1650	1550	1250	1000	850	715	625
110 = 4-3/8*	2000	1850	1700	1375	1100	925	775	685
120 = 4-3/4*	2250	2050	1850	1500	1200	1000	850	735
130 = 5-1/8*	2500	2250	2000	1625	1300	1075	925	775

\* Requires special pulley cover SM636 and special pulley bracket SM638.

**Changing the Pulley**

Remove pulley cover and pulley. Securely tighten the new chosen pulley.

**Caution** – Incomplete tightening may cause malfunctions. Also, be sure the pulley cover is correctly positioned to avoid rubbing against the pulley or the V-belt.

## Error Messages and Trouble Shooting

When an error message appears on the display the motor will stop automatically to protect the electronics of the motor and most importantly, to protect the motor circuit board.

If an error message occurs be sure to repeat the action that caused the error message. Many times if you reactivate the treadle and start the motor again, the error message will clear indicating this was a False error message requiring no further action.

There are two types of error messages:

- 1) False error messages
- 2) True error messages if the error is repeated.

False errors messages are common in areas where the electricity being supplied is unstable due to fluctuations, interference and spikes in electrical power supply to the motor. If these False error messages happen quite often it is recommended to contact a local electrician to see if the power supplied to the motor can be filtered. Doing so will eliminate False error messages.

True error messages do occur occasionally indicating a problem with an electrical component, the motor circuit board and on a very rare occasion, a faulty motor.

A complete and current listing of error messages and trouble shooting can be found at [www.endurosaves.com](http://www.endurosaves.com).

### E1: Motor Control Error

1. Most E1 error messages occur because of unstable power being supplied to the motor.
  - Release the pedal when the E1 error message occurs, then push down again to activate the motor. If the E1 error message no longer appears this was a False error due to unstable power.
2. If the E1 error message continues to appear:
  - Replace the motor circuit board with a new motor circuit board. Once the motor circuit board is replaced the E1 error message should no longer display.
3. If the E1 error message still appears after changing the motor circuit board, this is a very rare occurrence due to a faulty motor.

### E2: Motor Phase Signal Error (Hall Sensor Error)

1. It is possible to receive an E2 error message from unstable power which means it is a False error and the problem should resolve on its own.
2. Check the Hall sensor signal connector and socket (HER indicated) on the circuit board (Five Pin connector / socket), to make sure the 5 wires are connected to the board properly.
3. If the E2 error message continues to appear the motor is faulty and will not function properly. There is no repair possible and the motor must be replaced.



### **E3: Motor Protected Against Over Current**

1. It is possible to receive an E3 error message from unstable power which means it is a False error and the problem should resolve on its own.
2. Usually, the E3 error message occurs when the motor rotation is stuck by something or blocked by a heavy load when sewing. When this happens, more and more electrical current is driven to the motor until the electrical current exceeds the amount allowed by the motor. If this happens, the E3 error message is displayed and the motor is stopped to protect the motor from overload or burn out.
  - Remove the obstruction that is prohibiting rotation and the E3 error message should no longer display.
3. If nothing is blocking the sewing process and the motor can turn freely and the E3 error message is displayed, it is likely a faulty motor circuit board.
  - Replace the motor circuit board and the E3 error message should no longer display.

### **E5: Display Module and Control Module Communications Error**

1. It is possible to receive an E5 error message from unstable power which means it is a False error and the problem should resolve on its own.
2. E5 error message indicates a faulty LED display.
  - Check connections on the LED display module to be sure it is securely fastened to the motor circuit board. If the E5 error message no longer displays, then the connection to the motor circuit board was loose.
  - If the E5 error message continues to appear then replace the LED display module (No. SM109 for 4 digit readout) and the E5 error message should no longer display.
3. If the E5 error message continues to appear it indicates a faulty motor circuit board.
  - Replace the motor circuit board and the E5 error message should no longer display.



**E6: Pedal Position Sensor Error**

1. It is possible to receive an E6 error message from unstable power which means it is a False error and the problem should resolve on its own.
2. While the motor is on and the pedal position signal received by the motor circuit board is abnormal, it is possible to get the E6 error message. This is most common because of a faulty treadle sensor, misalignment of the sensor versus blocker, or improper operation such as the treadle is already pressed down before the motor is turned on.
  - Check the alignment of the sensor versus blocker on the treadle sensor plate. Adjust the position of the blocker if necessary (**see diagram of Proper Replacement of Treadle Sensor**).
  - Check the snap on connector of the treadle sensor and be sure it is securely attached. If the E6 error message no longer appears the connector was loose.
  - If the E6 error message continues to appear, then replace the treadle sensor (Single channel sensor for non-positioner motors No. SM68), and the E6 error message should no longer display.
  - When replacing the treadle sensor be sure it is properly aligned. If the treadle sensor is not aligned properly you may have a problem with the motor continuing to run after releasing the treadle (**see diagram of Proper Replacement of Treadle Sensor**).
3. If after replacing the treadle sensor and the E6 error message continues to appear the motor circuit board is likely faulty.
  - Replace the motor circuit board and the E6 error message should no longer display.

**Treadle Sensor Installation Description with Diagrams (Proper Replacement of Treadle Sensor)**

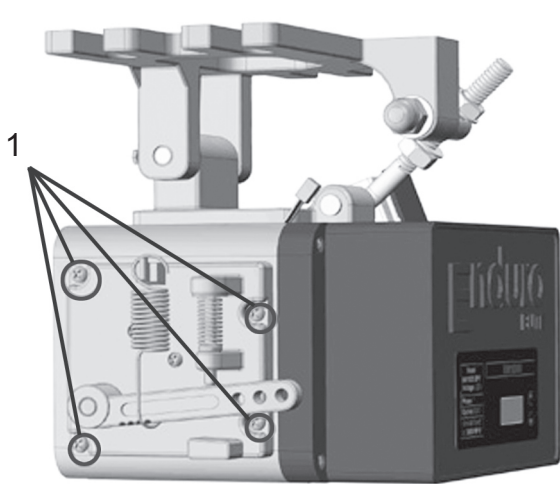

1. Remove the 4 screws on the treadle sensor plate.

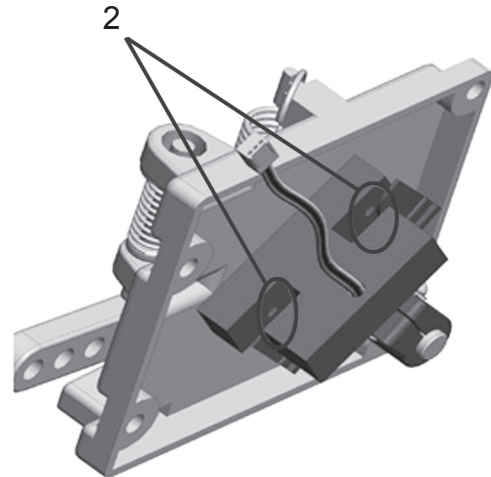

2. Check the channel sensor. It should have a red light when the cable is connected to the motor circuit board and the motor is powered on. Check the cable connection if there is no red light.

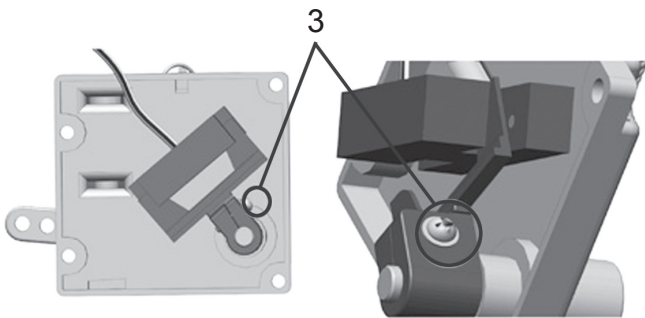

3. Check the relative position of the sensor and light blocker. If the light blocker is in a position that has blocked the light when the treadle is not pushed down, the motor will rotate. Adjust the blocker position if necessary by loosening the screw and tightening it again.

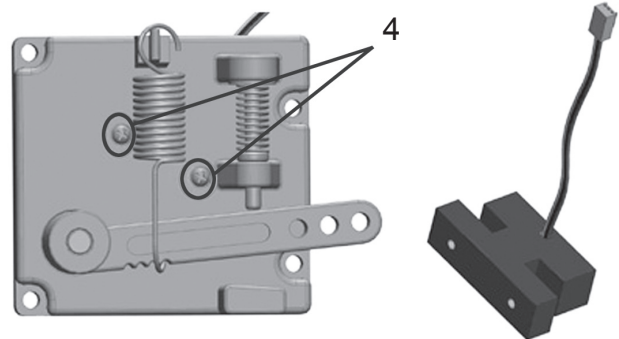

4. Change the sensor if necessary by unscrewing and reinstalling the two screws. Then connect the cable to the motor circuit board. The red light should appear when the motor is powered on indicating it is working.

**SM1050-2 PARTS LISTING**

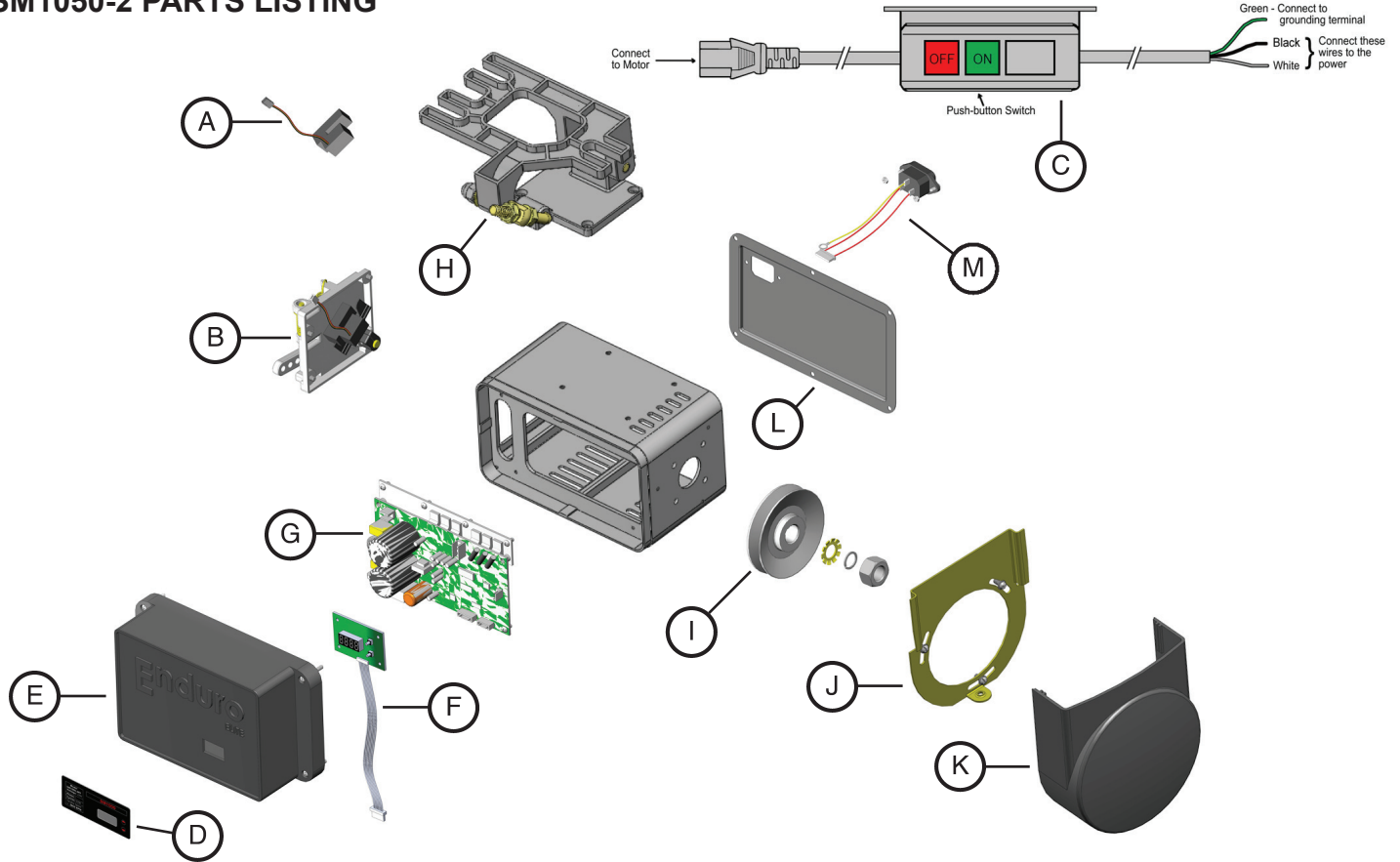

**No. Fig. Description**

SM68	A	Sensor only with screws (single channel for non-positioner motor)
SM103	B	Treadle sensor plate assembly complete with 4 screws (single channel for non-positioner motor) (877U)
SM78	C	Complete horizontal wire harness for 220 volt models (431C)
SM122	D	SM1050-2 label
SM108	E	SM1000 Elite series control box cover with 4 screws (431U Matte)
SM109	F	4 Digit LED display with screws
SM118	G	SM1050-2 circuit board with 6 Screws
SM113	H	Motor mounting bracket complete with 4 screws (877U)
SM50	I	50mm pulley with mounting hardware
SM60	I	60mm pulley with mounting hardware
SM75	I	75mm pulley with mounting hardware
SM80	I	80mm pulley with mounting hardware
SM90	I	90mm pulley with mounting hardware
SM100	I	100mm pulley with mounting hardware
SM110	I	110mm pulley with mounting hardware (must be used with SM636 pulley cover and SM638 bracket)
SM120	I	120mm pulley with mounting hardware (must be used with SM636 pulley cover and SM638 bracket)
SM130	I	130mm pulley with mounting hardware (must be used with SM636 pulley cover and SM638 bracket)
SM79	J	Pulley cover bracket with screws and washers
SM86	K	Pulley cover with screw and washer (431U Matte)
SM115	L	Rear motor cover panel for SM1050-2 with 6 screws (877U)
SM81	M	Power inlet receptacle with wires, terminals and screws complete